

## PARTS LIST

**Attachment Kit:  
P/N 08B15-SJC-100A**

2 XM tuner brackets

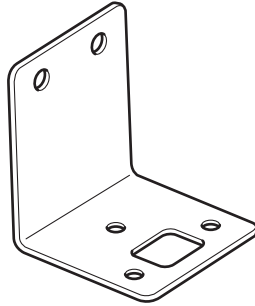

Bus cable

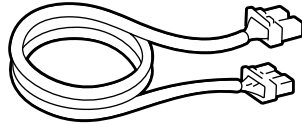

Wire tie with clip

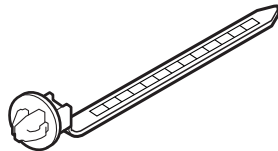

21 Wire ties

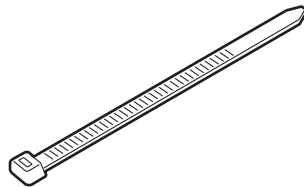

3 EPT sealers

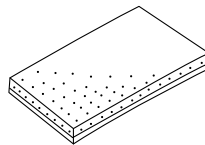

Cushion tape

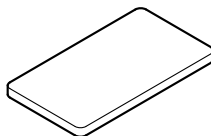

4 Flange nuts, 6 mm



4 Washer-screws, 5 x 8 mm



4 Washer-bolts, 6 x 16 mm



**XM Antenna (sold separately):  
P/N 08A15-0J1-100**

Antenna

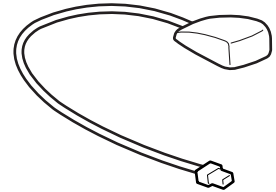

**XM Tuner (sold separately):  
P/N 08A15-3J1-101**

XM tuner

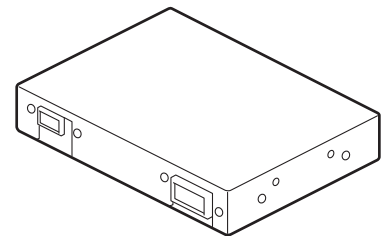

## TOOLS AND SUPPLIES REQUIRED

Phillips screwdriver  
Flat-tip screwdriver  
10 mm Combination wrench  
Ratchet  
8 mm and 10 mm Socket  
Isopropyl alcohol  
Shop towel  
Tape measure  
Utility Knife  
Scissors  
Felt-tip pen  
Torx wrench

### Illustration of the XM Radio System in the Vehicle

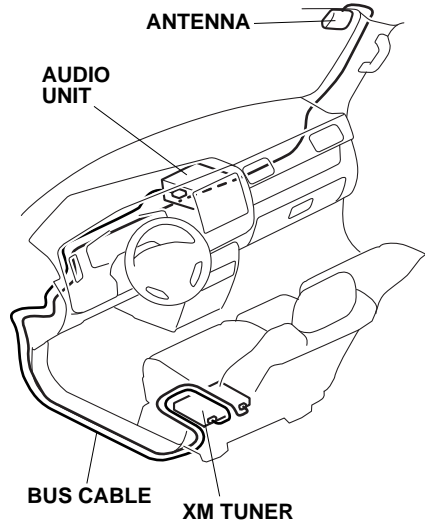

## INSTALLATION

**Customer Information:** The information in this installation instruction is intended for use only by skilled technicians who have the proper tools, equipment, and training to correctly and safely add equipment to your vehicle. These procedures should not be attempted by “do-it-yourselfers.”

1. Make sure you have the anti-theft code for the radio, then write down the radio station presets.
2. Disconnect the negative cable from the battery.

3. Remove the front passenger's grab rail:
  - Remove the screw covers (two retaining tabs for each cover).
  - Remove the two screws, and remove the grab rail.

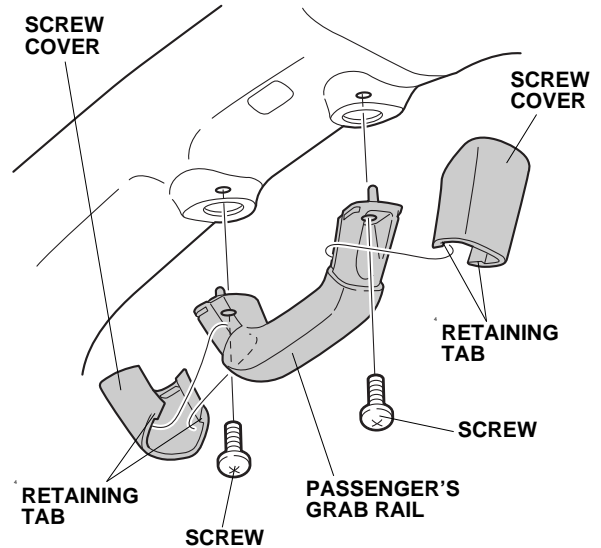

4. Pull away the weatherstrip from the passenger's A-pillar. Remove the passenger's A-pillar trim (two clips).

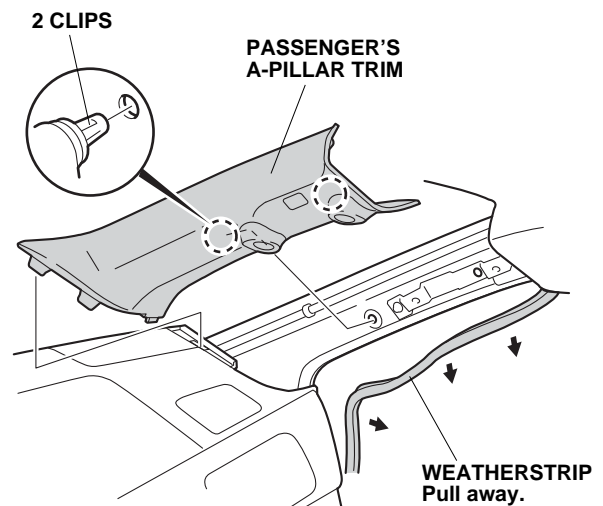

- Remove the right sunvisor screw cover (four retaining tabs). Remove the right sunvisor (two TORX screws, and unplug the vehicle connector).

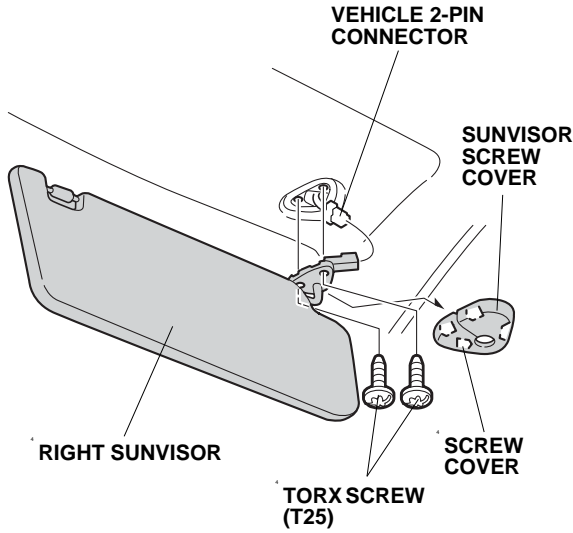

- Open the glove box. Remove the left and right stops from the glove box by releasing the retaining tabs.

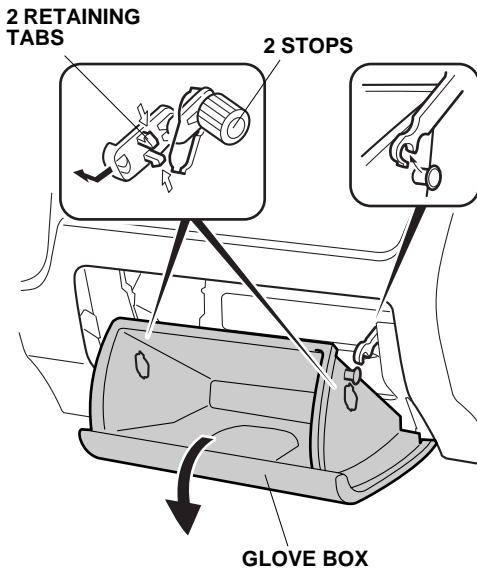

- Remove the dashboard left side cover (seven clips).

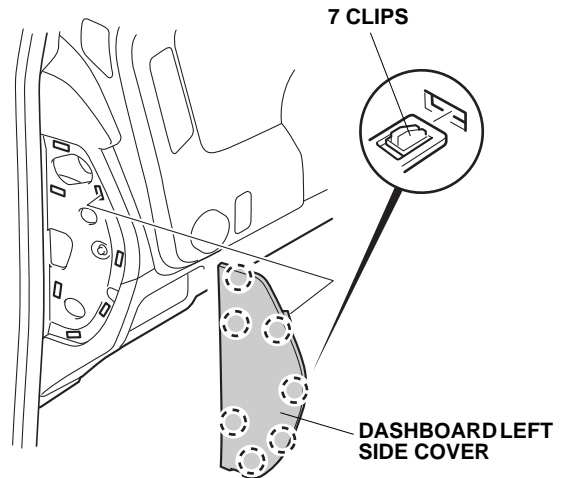

- Insert a flat-tip screwdriver wrapped with a shop towel into the grooves in the instrument panel and release the two clips. Pull the instrument panel out toward you to release the 18 clips. Unplug the vehicle connectors, and remove the instrument panel.

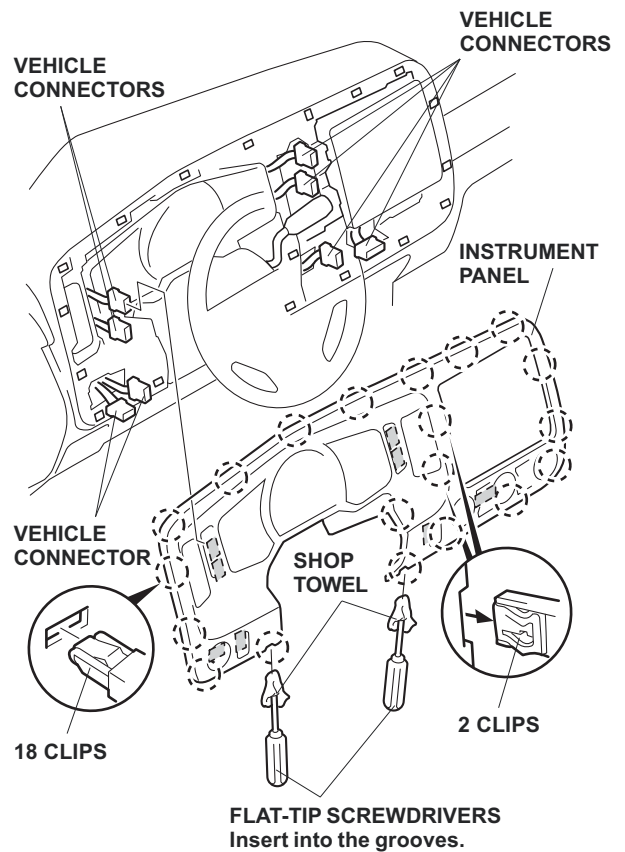

9. Remove the meter assembly (four self-tapping screws, and unplug the three vehicle connectors).

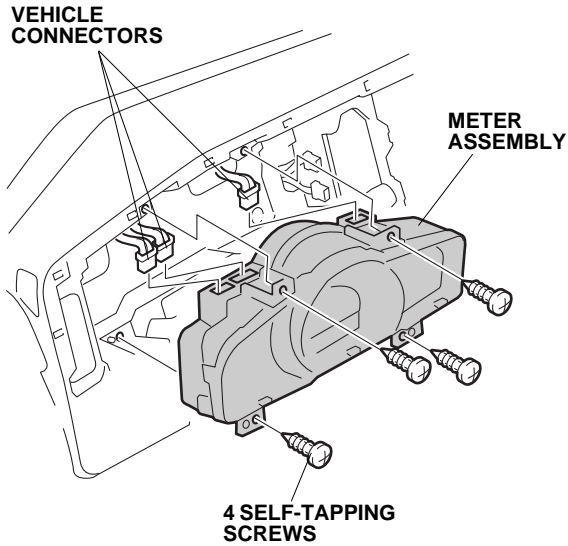

10. Remove the audio unit (five bolts, pull the audio unit out towards you, and unplug the vehicle connectors).

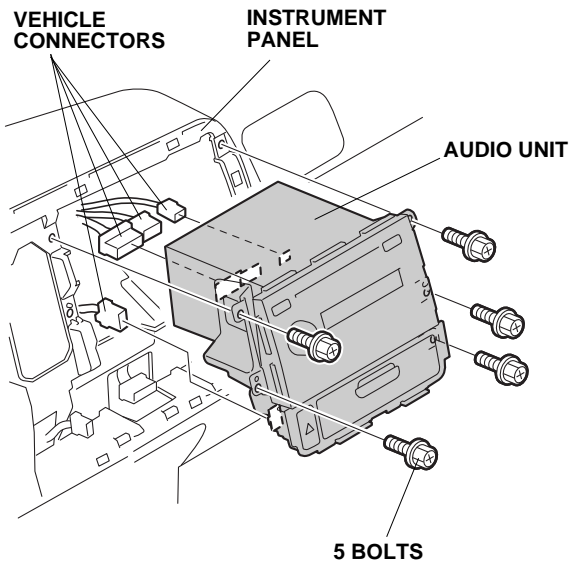

11. Remove the driver's dashboard lower cover:
- Remove one self-tapping screw.
  - Release the nine clips, and pull out on the driver's dashboard under cover.
  - Unplug the vehicle connectors, and disconnect the vehicle tube. Remove the driver's dashboard under cover.

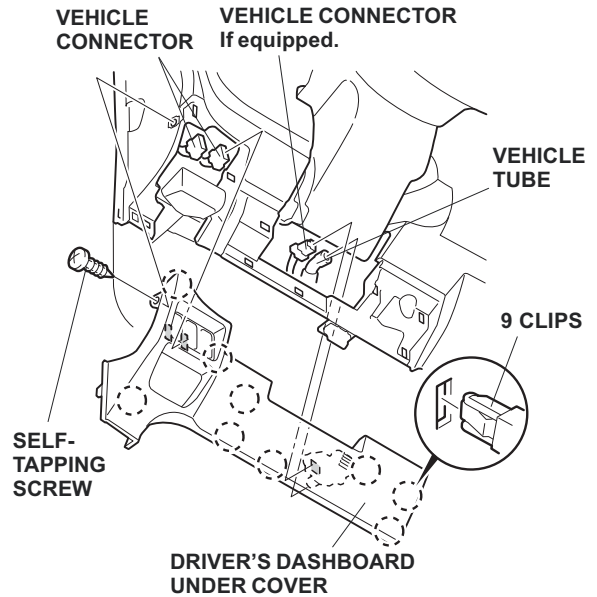

12. Remove the fuel fill door release handle. Remove the left front door sill trim (three clips and three retaining tabs).

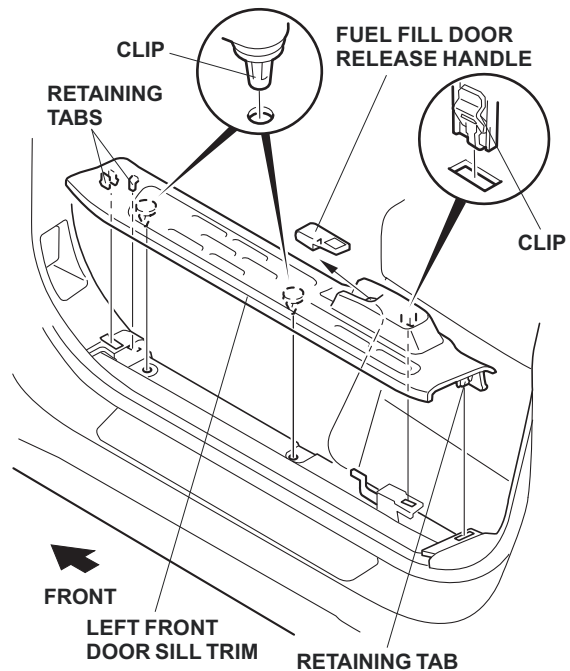

13. Pull away the weatherstrip from the driver's kick panel. Remove the driver's kick panel (one screw clip and one clip).

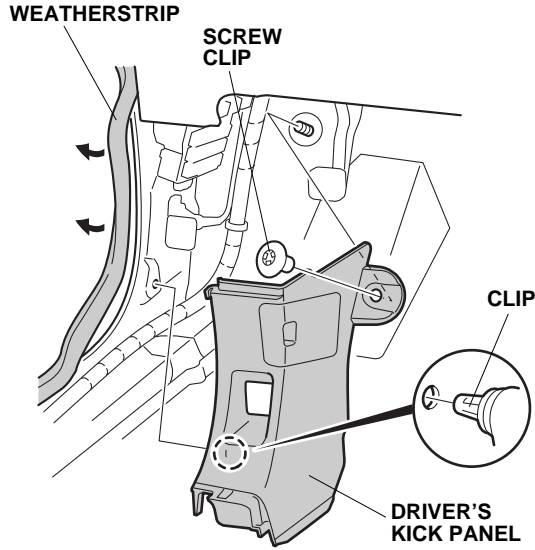

14. Remove the driver's seat frame rear cover (two clips and two hooks).

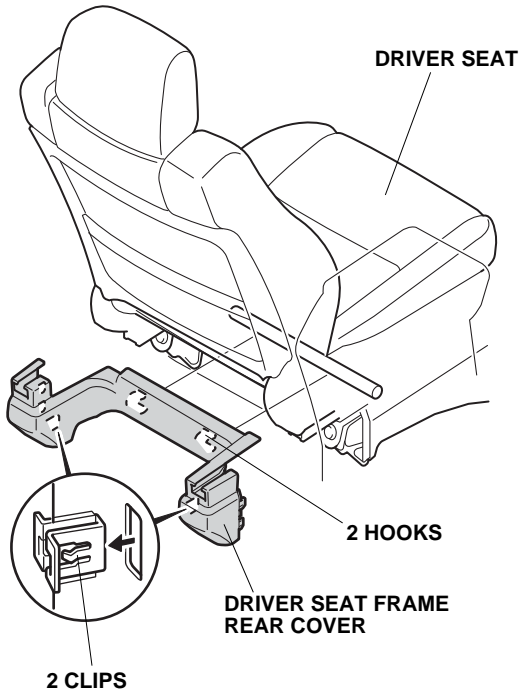

15. Using isopropyl alcohol on a shop towel, clean the right upper corner on the inside of the windshield. Remove the four adhesive backings from the antenna, and attach the antenna to the windshield at the location shown. Apply pressure to the antenna to adhere it to the windshield.

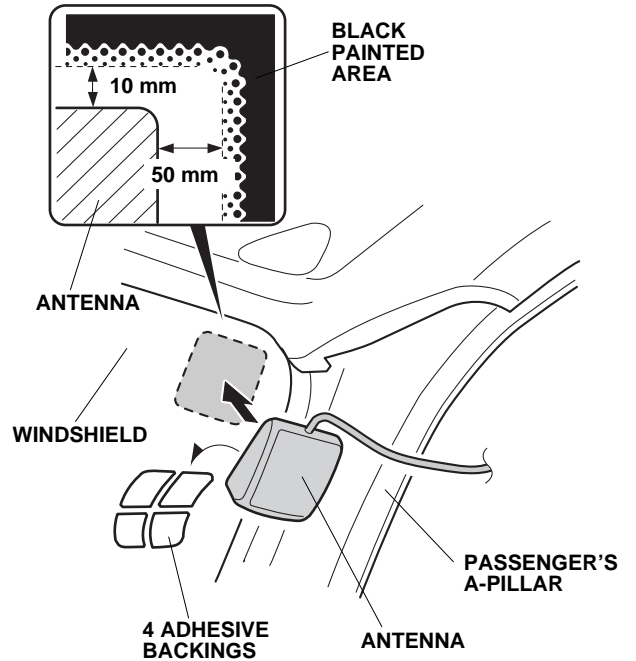

16. Route the antenna harness down the passenger's A-pillar along the vehicle harness. Secure the antenna harness to the vehicle harness with three wire ties in the areas shown.

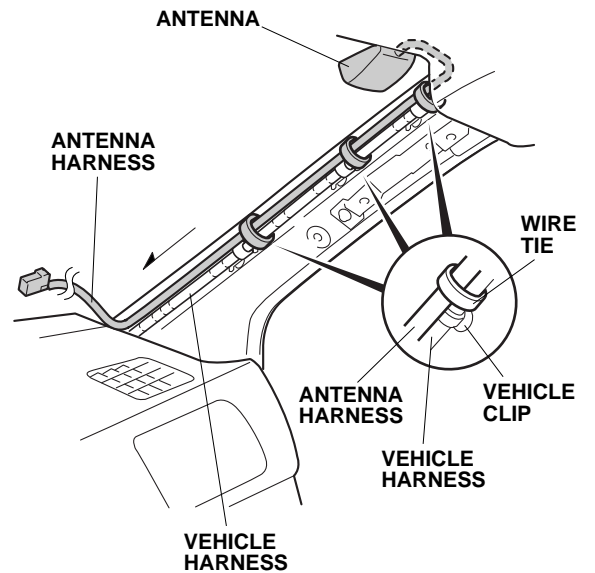

- Using a felt-tip pen, mark the antenna harness at the point where the harness touches the dashboard.

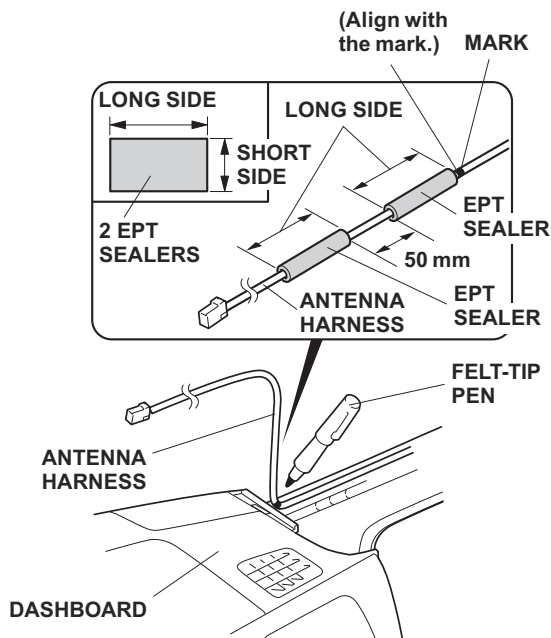

- Wrap two EPT sealers around the antenna harness at the locations shown.
- Route the antenna harness beside the dashboard and towards the glove box. Secure the antenna harness to the vehicle harness with one wire tie.

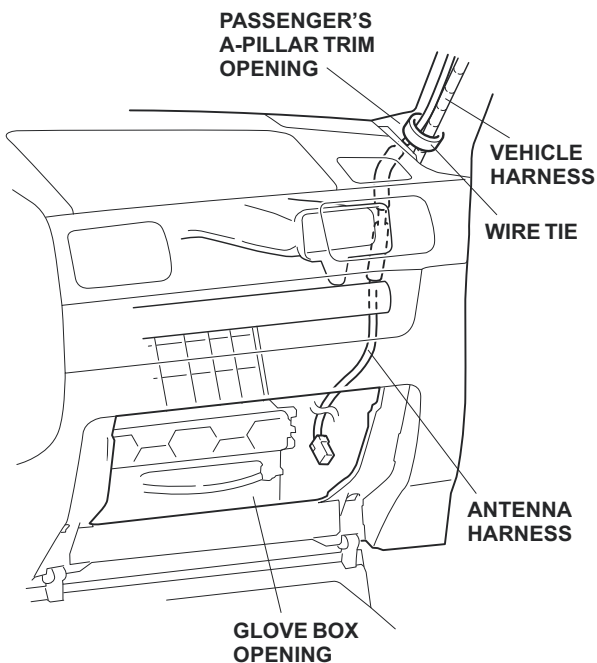

- Inside the glove box opening, route the antenna harness along the vehicle harness towards the driver's side of the vehicle. Secure the antenna harness to the vehicle harness with three wire ties in the areas shown.

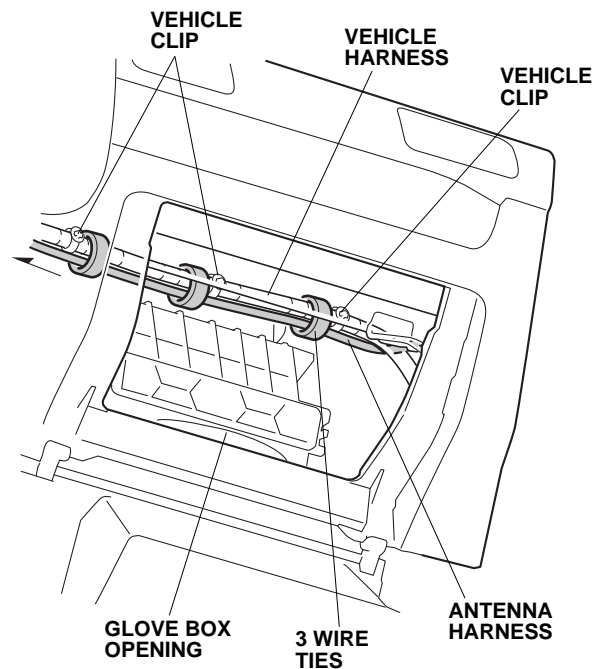

- Route the antenna harness past the audio unit opening, and secure the antenna harness to the vehicle harness with one wire tie.

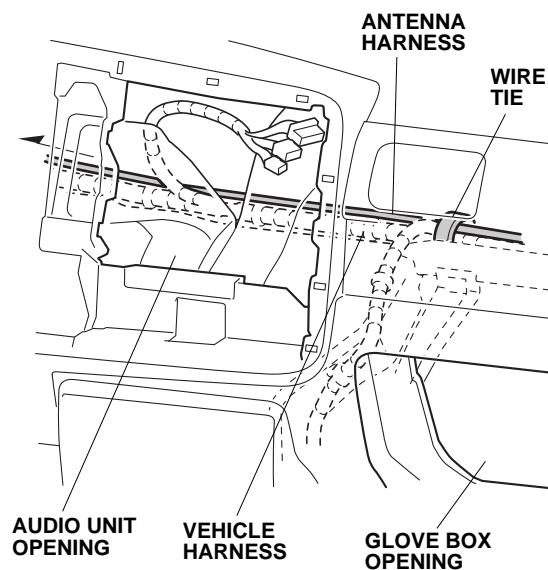

22. Route the antenna harness as shown and secure it to the vehicle harness with two loosely-installed wire ties.

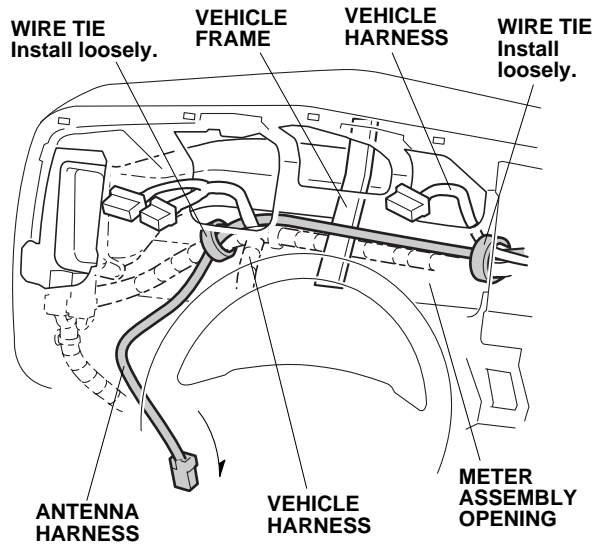

23. Route the antenna harness along the vehicle harness and secure it to the vehicle harness with four loosely-installed wire ties.

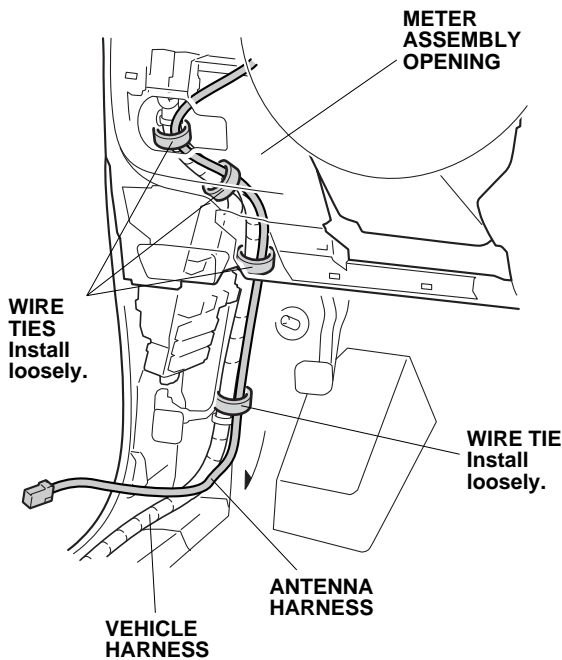

24. Route the antenna harness as shown and secure it to the vehicle harness with four loosely-installed wire ties.

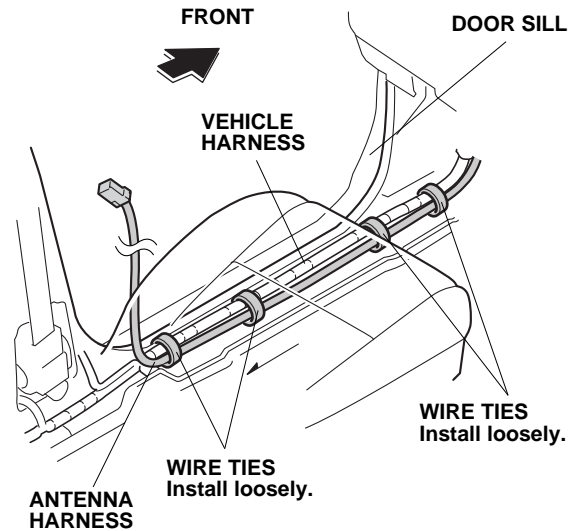

25. Route the antenna harness and the bus cable under the floor carpet. Pull them out of the cutout in the floor carpet.

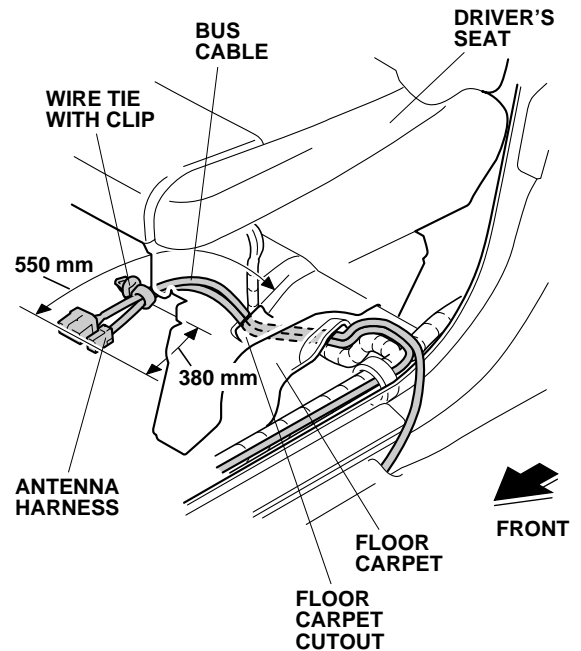

26. Pull the antenna harness and the bus cable past the cutout in the floor carpet to the measurement shown.  
 27. Bind the antenna harness and bus cable together at the measurement shown using a wire tie with clip.

28. Install two XM tuner brackets to the XM tuner with four 5 x 8 mm washer-screws.

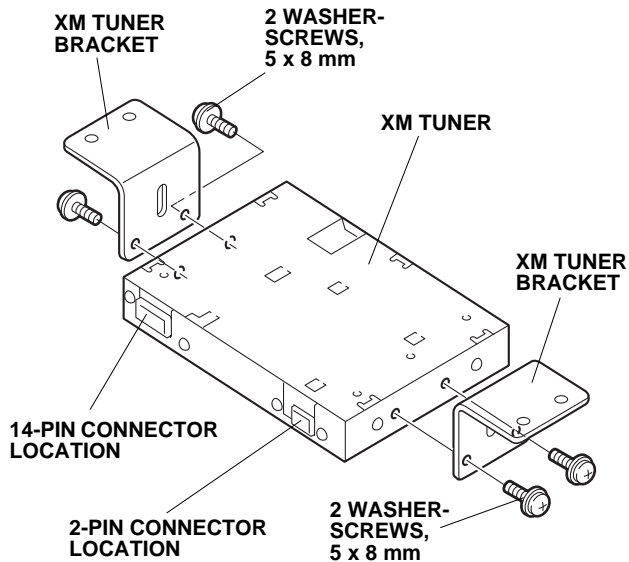

29. Install the XM tuner brackets to the driver's seat panel with four 6 x 16 mm washer-bolts and four 6 mm flange nuts.

NOTE: The vehicle may be equipped with a seat plate with welded nuts. If so, the four flange nuts are not used.

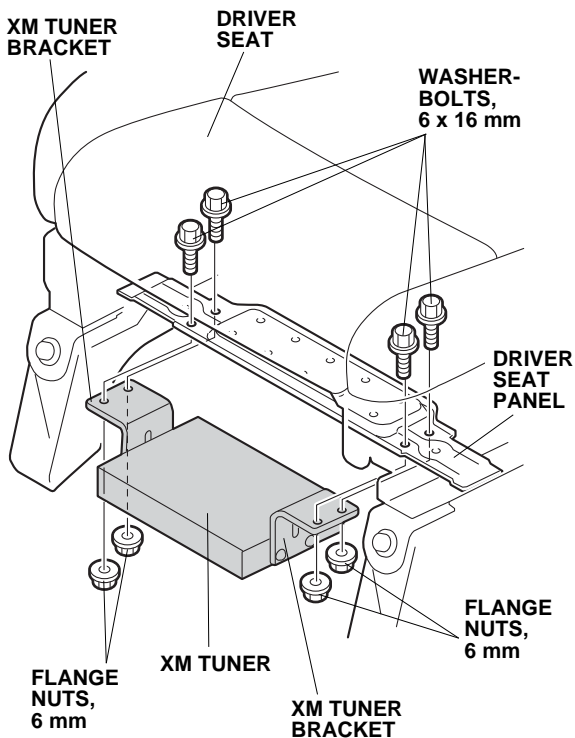

30. Connect the antenna harness 1-pin connector and bus cable 14-pin connector to the XM tuner.

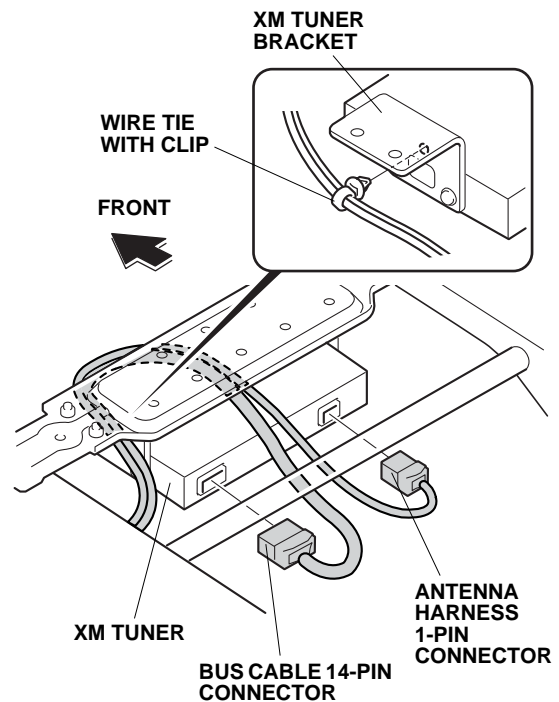

31. Install the wire tie with clip, installed in step 27, onto the XM tuner bracket.
32. Using isopropyl alcohol, clean the surface where the EPT sealer will be attach. Attach the antenna harness and bus cable to the XM tuner using a cushion tape as shown.

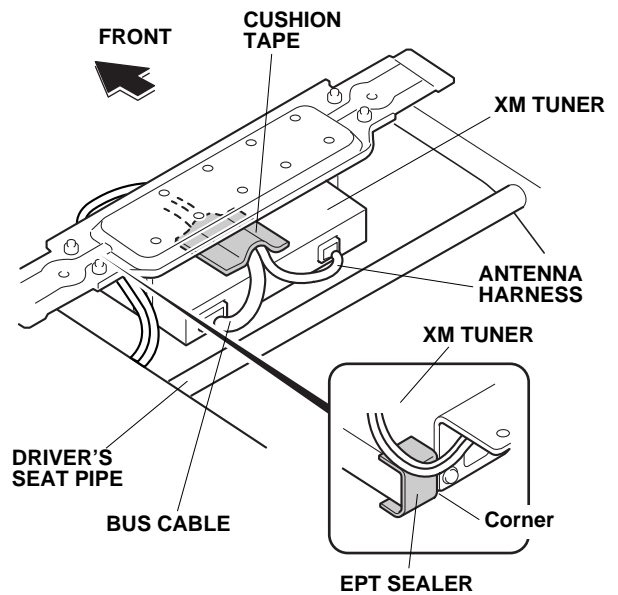

33. Attach the EPT sealer to the corner of the XM tuner as shown.



34. Route the bus cable along the antenna harness toward the front. Secure it to the vehicle harness by tightening the four wire ties loosely-installed in step 24.

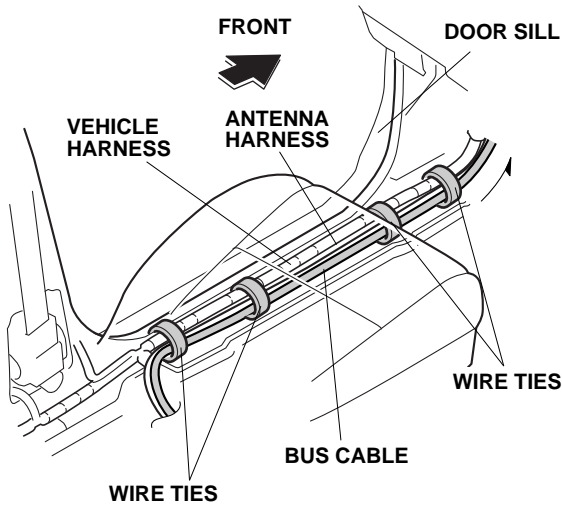

35. Route the bus cable along the antenna harness as shown. Secure it to the vehicle harness by tightening the four wire ties loosely-installed in step 24.

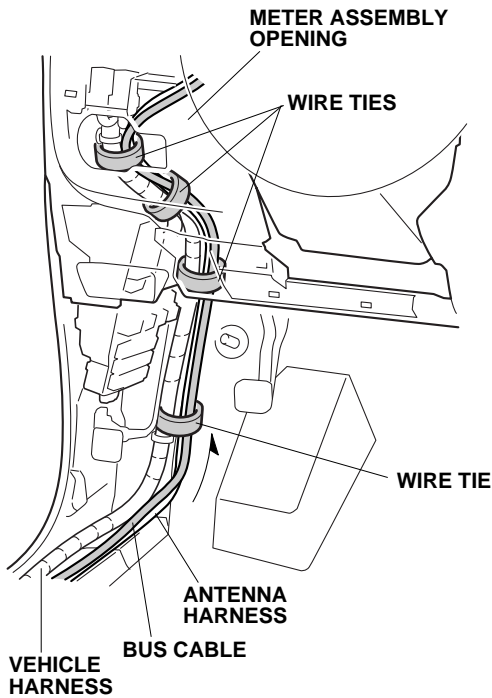

36. Route the bus cable as shown. Secure the bus cable and antenna harness to the vehicle harness by tightening the two wire ties loosely-installed in step 22.

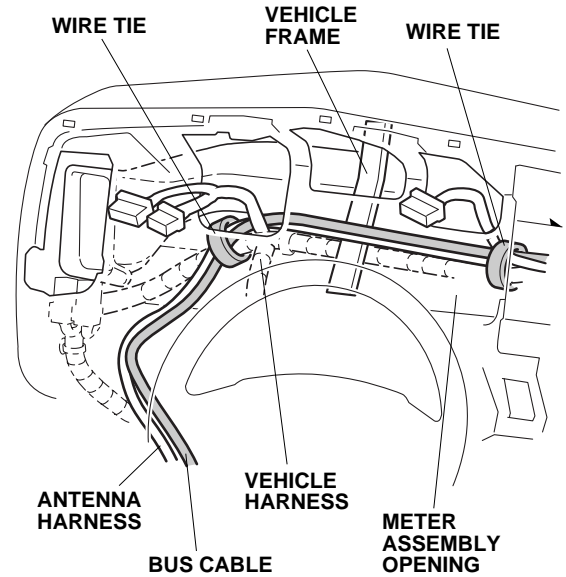

37. Align the end of the bus cable connector with the end of the vehicle 20-pin connector and secure the bus cable to the vehicle harness using a wire tie.

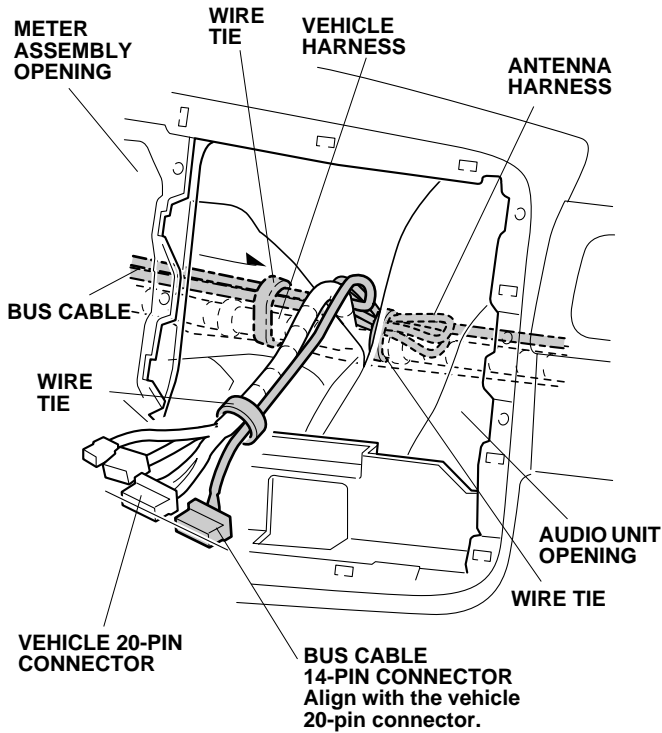

38. Secure the bus cable and antenna harness to the vehicle harness using a wire tie. Bundle the excess antenna harness and secure it to the vehicle harness using a wire tie.
39. Plug the bus cable 14-pin connector and vehicle connectors to the audio unit/player.

**With MP3 Player**

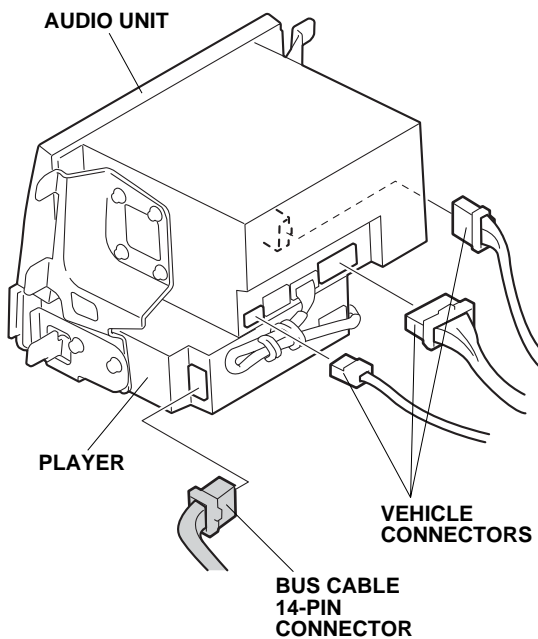

**Without MP3 Player**

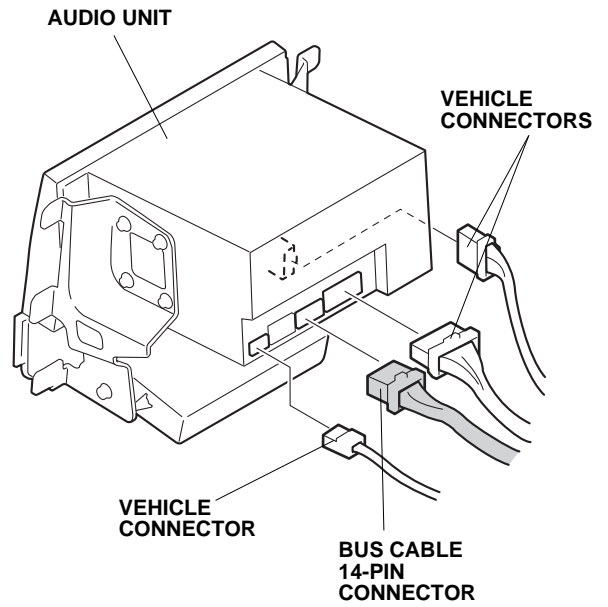

40. Reinstall the audio unit.

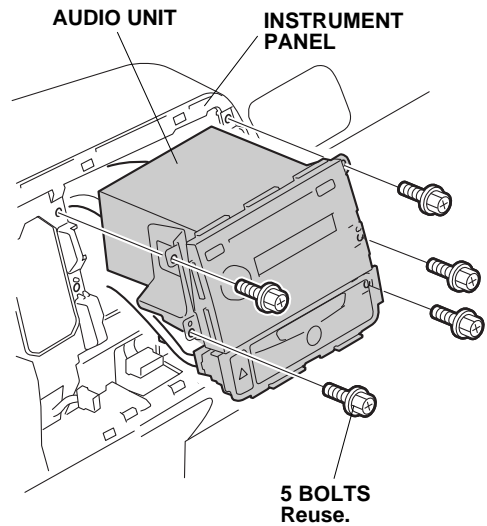

41. Slide the driver's seat back and forth to check that the antenna harness and bus cable are not too tight or too loose.

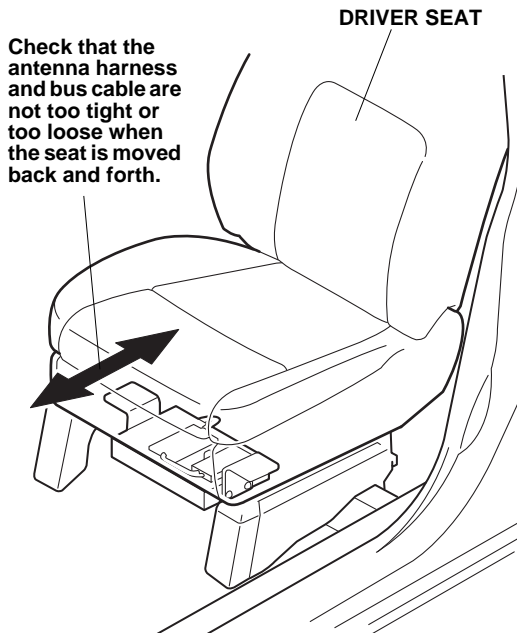

42. Check that all wire harnesses are routed properly and all connectors are plugged in.
43. Reconnect the negative cable to the battery.
44. Enter the customer's audio anti-theft code, and reset the radio station presets.
45. Set the clock.
46. Check the operation of the XM radio system according to the vehicle's owner's manual.
47. Reinstall all removed parts.
48. Initialize and test the front window auto up/down function.